

## PH62 – 350°C

### Einsatzbereiche:

- Lebensmittelindustrie (FCM konform)
- Pharmaindustrie
- Kosmetikindustrie
- Trocknungsprozesse
- Folien schrumpfen
- Beschichtungsprozesse
- Sterilisationsprozesse

### Applications:

- Food industries (FCM compliant)
- Pharma industries
- Cosmetics industries
- Drying processes
- Shrinking processes
- Covering processes
- Sterilization processes

### Highlights:

- Über Flansche in Rohrleitungen integrierbar
- Hohe Energiekosteneinsparung durch Umluftbetrieb bis 350°C
- Zugelassen für die Lebensmittelindustrie
  
- Easy to install into pipe systems
- Saves energy and money, because of recycled air system up to 350°C
- Compliance to food industries

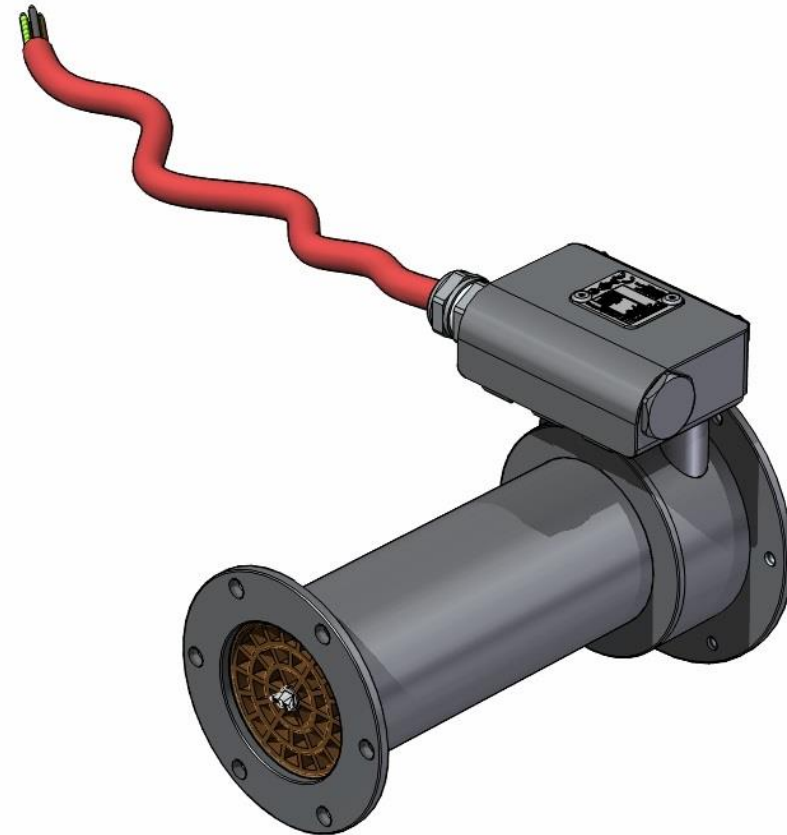

## Technische Daten / Technical datas:

Artikelnummer Code	5208202	5208200	5208201	5208203
Leistung Power	8,3 kW	4,4 kW	9,0 kW	11,0 kW
Spannung Voltage	3 x 230 VAC	3 x 400 VAC		
Strom Current	3 x 20,8 A	3 x 6,4 A	3 x 13,0 A	3 x 15,9 A
Temperatur Temperature T <sub>OUT max.</sub>	700°C			900°C
Temperatur Temperature T <sub>IN max.</sub>	350°C			
Betriebsdruck Pressure	1 bar			
Min. Luftmenge Min. Airvolume	740 l/min	450 l/min	680 l/min	750 l/min
Länge Lenght	183 mm			245 mm
Breite Width	116mm			
Höhe Height	143,5mm			
Gewicht Weight	3,3 kg			4,3 kg
Anschlusskabel Power supply cord	SiHF 4x2,5 mm <sup>2</sup> L=5 m			
Schutzklasse Protection Class	KI.1 ≡			
Konformität Compliance	CE			

**Maße / Dimensions:**

Seitenansicht / side view

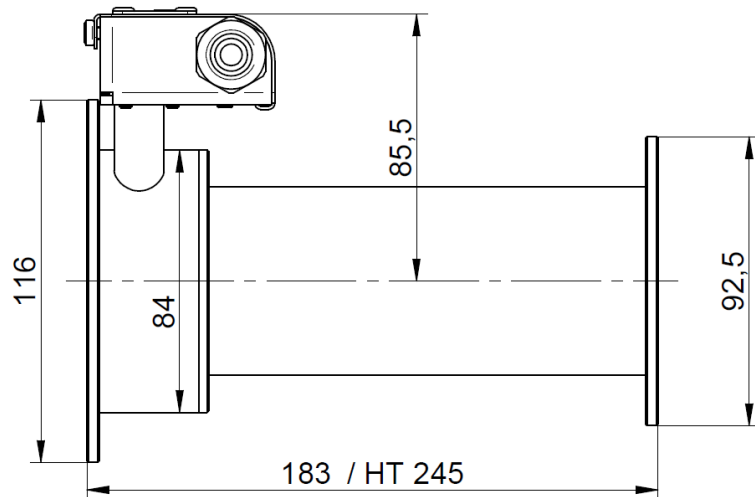

Vorderansicht / front view

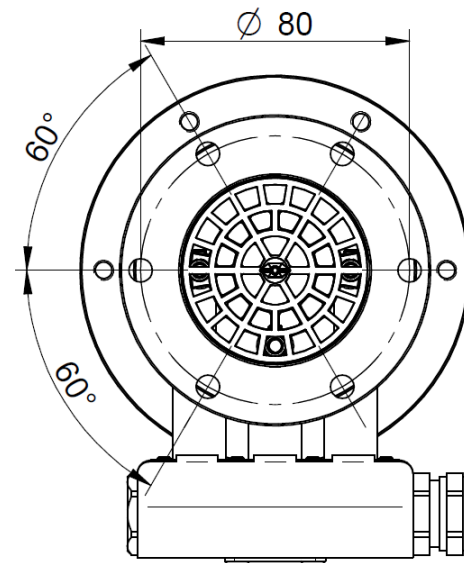

Rückansicht / back view

